

SPARTAN FIRE, LLC.
EPHRATA, PA 17522

CHASSIS: SPARTAN GLADIATOR LFD
 ENGINE: CUMMINS ISX-15 500 HP
 TRANSMISSION: ALLISON 4500 EVS
 AXLES: 23,000 LB.FRONT/58,000 LB. REAR
 MODEL: C34R-110 AERIAL LADDER
 WATER/FOAM: 500 / 0 GALLONS
 PUMP: WATEROUS CSU 2000 GPM
 FOAM SYSTEM: N/A
 GENERATOR: N/A

COMPARTMENT DIMENSIONS

I.D.	DOOR OPENING	INTERIOR DIMENSIONS
L1	23.50w x 19.62H	23.63w x 21.25h x 25.25D
L2	36.63w x 67.32H	36.88w x 70.75h x 24.88D
L3	55.25w x 37.19H	55.50w x 40.63h x 24.88D
L4	55.25w x 29.00H	55.50w x 32.37h x 11.00D UPPER 24.00D LOWER
L5	44.00w x 61.88H	44.25w x 62.50h x 11.00D UPPER 24.00D LOWER
R1	23.50w x 19.62H	23.63w x 21.25h x 25.25D
R2	36.63w x 67.32H	36.88w x 70.75h x 24.88D
R3	55.25w x 37.19H	55.50w x 40.63h x 24.88D
R4	55.25w x 29.00H	55.50w x 32.37h x 11.00D
R5	44.00w x 61.88H	44.25w x 62.50h x 11.00D UPPER 24.00D LOWER

GROUND LADDERS:
 ONE DUO-SAFETY 35 FT. 1200A 2-SECTION
 ONE DUO-SAFETY 24 FT. 900A 2-SECTION
 TWO DUO-SAFETY 20 FT. 875DR ROOF
 ONE DUO-SAFETY 16 FT 875DR ROOF
 ONE DUO-SAFETY 14 FT 701 FRESNO
 ONE DUO-SAFETY 10 FT. 585A FOLDER
 ONE DUO-SAFETY 14 FT. 775DR ROOF IN FLY SECTION
 ONE LITTLE GIANT DEFENDER ON TOP OF PUMP
 ONE FHU NH-12 NATIONAL HOOK
 ONE FHU NH-10 NATIONAL HOOK
 ONE FHU RH-8 NEW YORK ROOF HOOK
 ONE FHU RH-6 NEW YORK ROOF HOOK

CUSTOMER

THIS DRAWING IS A CLOSE APPROXIMATION OF YOUR FIRE APPARATUS. IN ALL CASES WHERE THE DRAWING AND THE WRITTEN SPECIFICATION DIFFER, THE SPECIFICATION SHALL PREVAIL. PLEASE WORK WITH YOUR DEALER TO ASSURE THAT THE WRITTEN SPECIFICATION REPRESENTS WHAT YOU WANT IN YOUR FINISHED PRODUCT. SPARTAN EMERGENCY RESPONSE BUILDS TO THE WRITTEN SPECIFICATION, NOT THE DRAWING TO ASSURE THAT YOUR NEEDS ARE MET.

PROPRIETARY AND CONFIDENTIAL

THE INFORMATION CONTAINED IN THIS DRAWING IS THE SOLE PROPERTY OF SPARTAN EMERGENCY RESPONSE. ANY REPRODUCTION IN PART OR AS A WHOLE WITHOUT THE WRITTEN PERMISSION OF SPARTAN EMERGENCY RESPONSE IS PROHIBITED. SPARTAN MOTORS USA, INC. D/B/A SPARTAN EMERGENCY RESPONSE.

REV	DATE	DESCRIPTION	NAME
4	6/21/23	REVISED TO REFLECT CHANGE ORDER "A"	WB
3	1/23/23	PRECONSTRUCTION MEETING	WB
2	10/11/22	FIRST FACTORY REVIEW	WB
1	10/05/22	CUSTOMER REQUESTED REVS	DS
0	09/05/22	INITIAL PROPOSAL	DS

SCALE: NOT TO SCALE

THEILLS-ROSEVILLE FIRE DISTRICT
THEILLS, NEW YORK

TRUCK NUMBER:
000000 3-012-0138

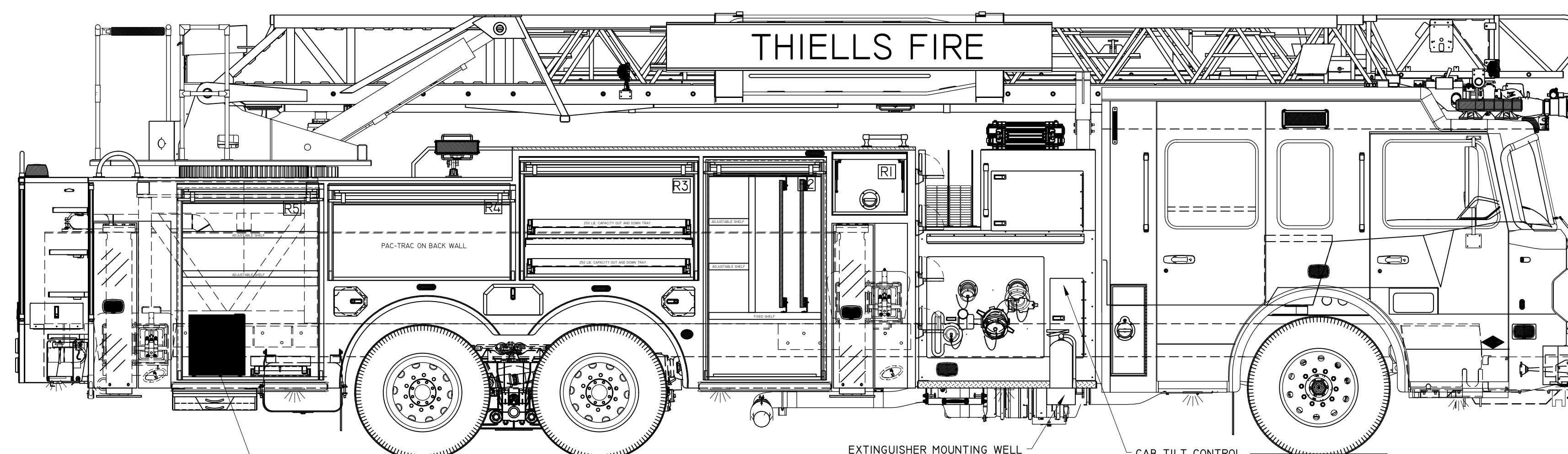
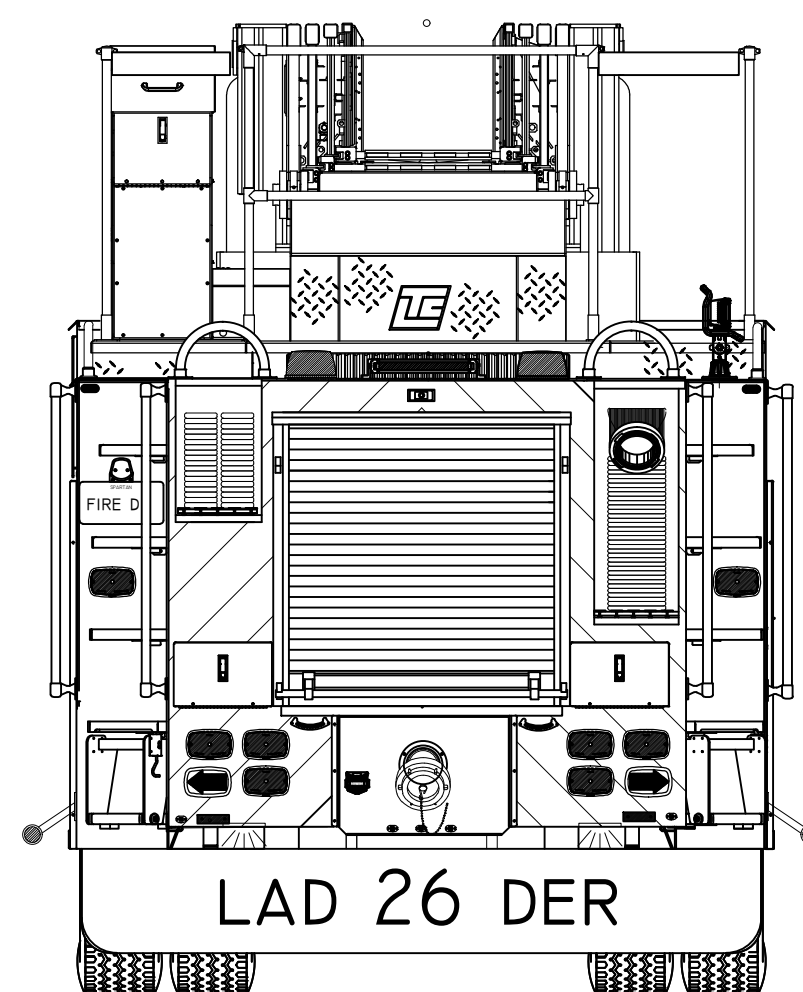
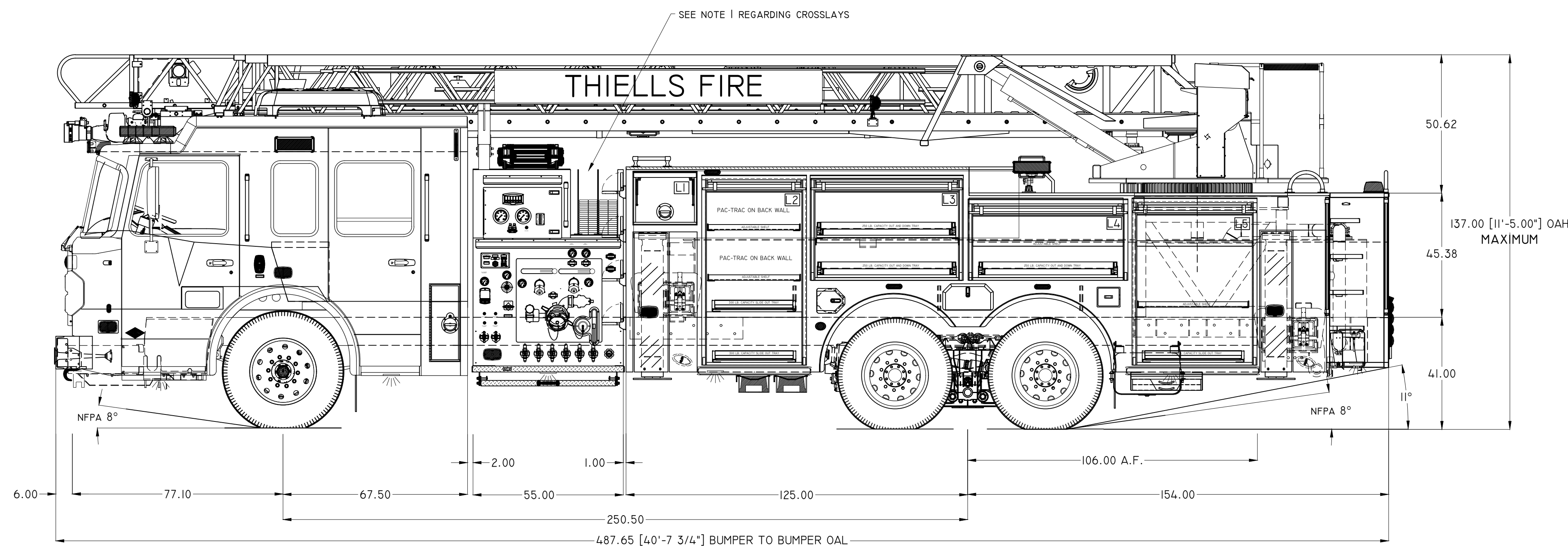
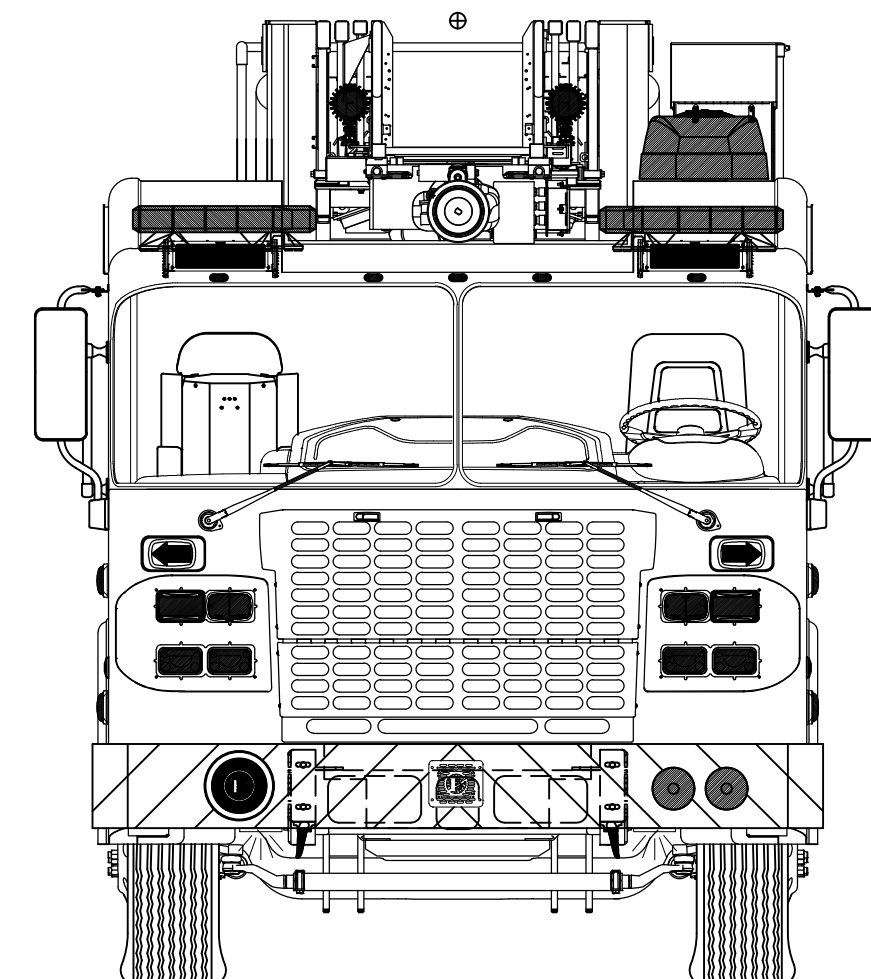
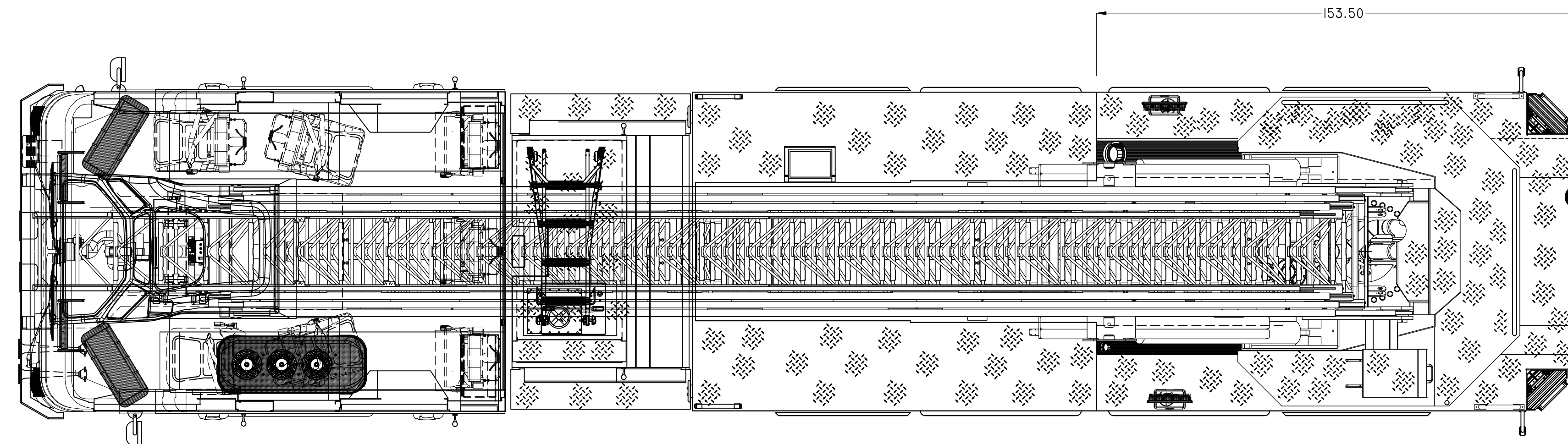
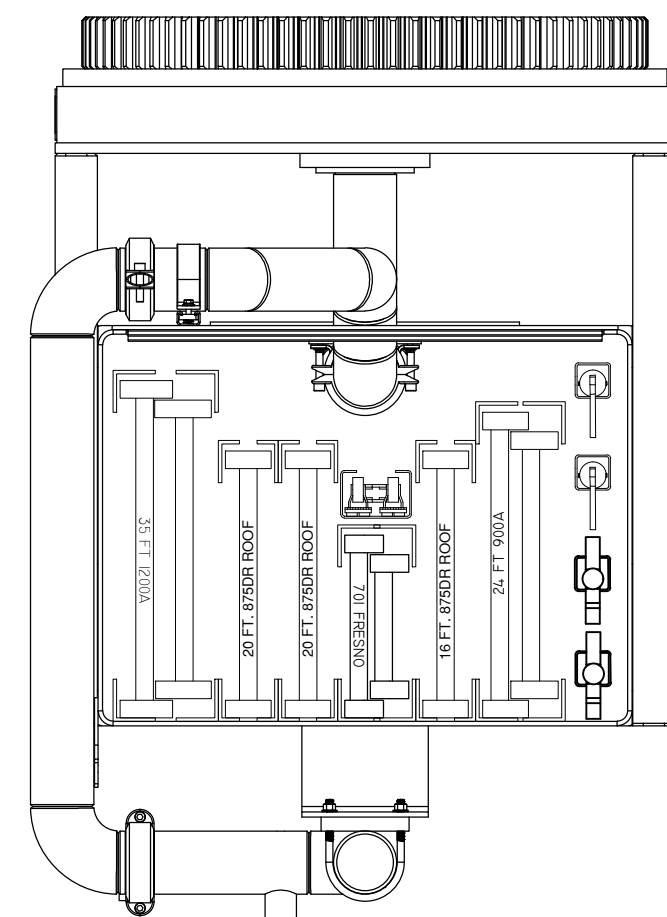

NORCOLD MODEL NR740 REFRIDGERATOR
20.5" H x 18.5"W x 21" D

NOTE 1: CROSSLAY SPACE WILL BE CONFIGURED TO ALLOW ONE (1) 1-3/4" DOUBLE STACK AND ONE (1) 2-1/2" DOUBLE STACK HOSE LOAD ALTHOUGH THE F.D. WILL LOAD TWO (2) 1-3/4" DOUBLE STACK CROSSLAYS FOR NORMAL OPERATIONS.